



TARD

Current Transformers Accessories for the RD family

DESCRIPTION

Toroidal Transformers (TARD) are designed for the RD family of Earth Leakage Relays to detect current leakages due to loss of ground insulation. The TARD must be installed so that all active wires go through its window (L1, L2, L3, N). This means that any shield or armour must not pass through, ensuring that the ELR receives a signal proportional to the vectorial sum of the line and neutral currents.

The secondary coil insulation is guaranteed by a 2.5 kV test at main frequency for 1 minute.

The TARD are made in highly permeable magnetic materials and are available with internal diameters from 35 mm to 210 mm in closed or split format, allowing the installation on bars and cables up to considerable dimensions. The enclosure is made with insulating and self-extinguishing covers, provided with accessories for the fixing on DIN guides. The connection between the RD and the TARD should be made with twisted shielded cables.

The connection length should be as short as possible and additionally far away from power cables and other devices that may cause electromagnetic disturbances.

SPECIFICATIONS

Nominal Frequency: 47 to 63 Hz

Turns ratio: 500/1

Insulation test: 2,5 kV 50/60 Hz (60 sec.)

Working temperature: -10° to 55°

Terminal blocks: 4.0 mm² / 10 AWG

Cover material: UL94-V2



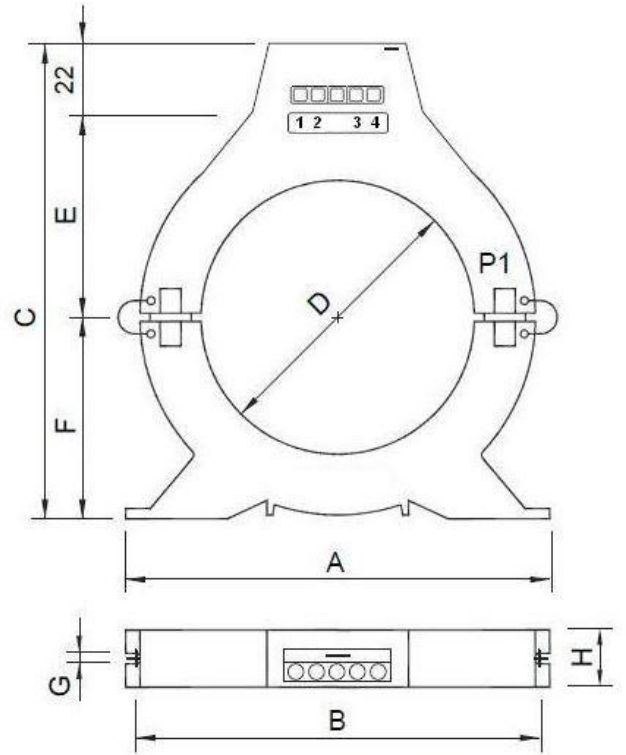
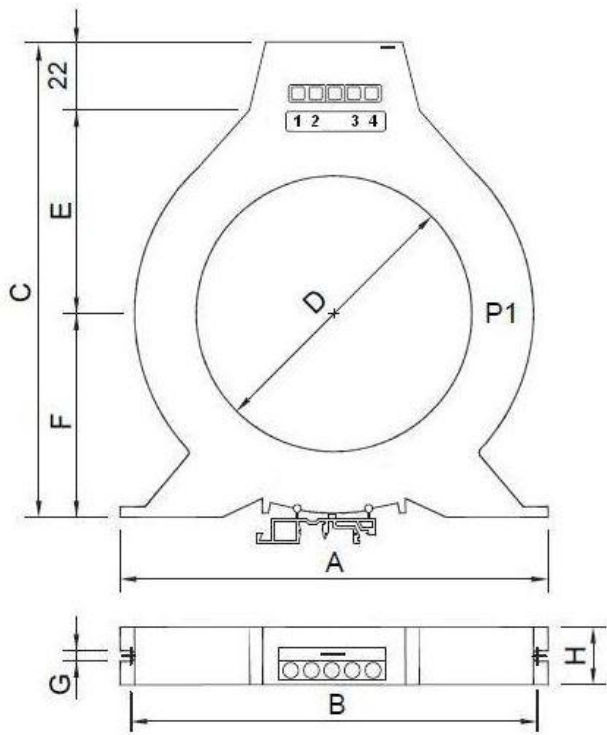

CLOSED CORE									
DIAMETER (mm)	WEIGHT (kg)	DIMENSIONS (mm)							
		A	B	C	D	E	F	G	H
35	0.2	100	92	105	35	42	40	8.2	28.5
60	0.3	125	115	133	60	66	63	8.6	28.5
80	0.4	146	136	152.5	80	62	58	6.8	28.5
110	0.5	178	166	180	110	80	78	9	28.5
160	1.4	276	262	273	160	132	130	8.5	44
210	1.7	325	310	332	210	155	160	8.5	44

SPLIT CORE									
DIAMETER (mm)	WEIGHT (kg)	DIMENSIONS (mm)							
		A	B	C	D	E	F	G	H
110	1.4	236	220	239	110	105	105	6.6	44
160	1.8	276	260	281	160	130	130	8.5	44
210	2.2	326	310	319	210	155	155	8.5	44

